

Presray Pneuma-Seal[®]

DESIGN GUIDE

**ONE GREAT CONCEPT
THREE GREAT APPLICATIONS**



SEALING



CLAMPING



ACTUATING



ENGINEERED PRODUCTS

www.pawling.com

The Solution to Sealing

1. Horizontal or Vertical **sliding** doors.
2. Hinged doors with **flush thresholds** for easy personnel or equipment access.
3. **Large** fabricated doors or other closures where it is impractical to machine the sealing surfaces to accommodate conventional seals and gaskets.
4. Processing equipment where **rapid sealing and unsealing** is required.



Doors and other closures can be positively sealed by using Pneuma-Seal. The seal is inflated with air or other fluid by a pressure-regulated supply system (which can also be furnished by us). When pressurized, the seal conforms to uneven surfaces and provides an efficient, reliable barrier to dust, moisture, contaminants, and/or pressure differential. Operating pressures are usually in the range of 10 to 35 PSI but some of the seals can

be designed to operate at lower pressures, in the order of 5 PSI or less, or at higher pressures of 100 PSI or more. Expansion capabilities, the ability to close a "gap", vary from cross section to cross section. Large "gaps" may be accommodated but it should be noted that as the gap increases, the pressure required to seal against a given pressure differential increases, thereby decreasing the seal's flex life.

The Solution to Clamping and Actuating



Pneumatic Clamps

When inflated, the clamp provides uniform controlled pressure to firmly clamp pieces together during bonding operations or to hold pieces in place during machining or cutting operations. Typical applications include the bonding of airframe components and stopping large pharmaceutical bottles on a conveyor line.

Pneumatic Actuators

The expanding Pneuma-Seal moves and repositions other components which exert pressure to actuate switching devices, to open and close air or hydraulic passages, or to clamp mechanical components. In a typical application, the pressurized Pneuma-Seal effects the desired motion and mechanical springs return the components to their normal open or closed position.

Pneuma-Seal Construction

Pneuma-Seal is available in four different types of construction:

- Extruded with vulcanized joints or ends
- Extruded and either fully preformed or with preformed corners, with vulcanized joints or ends
- Fully molded, seamless (no vulcanized joints)
- Fully molded, seamless (no vulcanized joints), and reinforced with Nylon, Nomex®, Kevlar®, fiberglass or Dacron® fabric

The extruded construction seals are offered for applications where economy is of primary concern. However, in applications involving high pressure and/or repeated, continuous use, where safety and reliability are of major importance, the molded fabric-reinforced construction is recommended. The molding process minimizes weak points at "spliced" joints and the fabric reinforcing gives additional structural integrity assuring better resistance to rupture and tear, thereby providing superior flex life.

Presray Pneuma-Seal

Pawling Engineered Products is a vertically integrated business designing, selling and manufacturing the inflatable Pneuma-Seal® product line and other custom rubber products of Presray Corporation as well as the compounds and rubber and plastic extrusions of Pawling Corporation.

This new Design Guide is filled with information, which should prove valuable to you when working with new or changing requirements in your business. Please give us a call at 845-855-1000 with questions on how our capabilities might help solve problems for your specific application.

Table of Contents

The Solution to Sealing	2
Applications	4
Applications in Detail	5
Typical Configurations	6
Materials	7
Type 1 Pneuma-Seal	8
Retention Systems for Type 1	9
Type 2 Pneuma-Seal	10
Type 3 Pneuma-Seal	11
Retention Systems for Type 3	12
Type 4 Pneuma-Seal	12
Type 10 Pneuma-Seal	13
Retention Groove Design for Type 10	13
Type 7 Pneuma-Seal	14
Other Pneuma-Seal Types	14
Sealing Small Diameters	14
2-Piece Seals	15
End Configurations	15
Mechanical Interlocking Ends	15
End Configurations for Types 1 and 2 Seals	15
End Configurations for Type 3 Seals	16
End Configurations and Clamps for Type 10 Seals	16
Corner Configurations	17
Sealing Rectangular Openings with Radially Outward Expanding Seals	17
Air Connections	18
Air Connections for Types 1,2,3,4 and 7	18
End Connections for Types 1,2,3,4 and 7	19
Air Connections for Type 10 Seals	19
Custom Rubber Fabrications	20
Special Molded Cross Sections	21
Fabric Reinforced Compression Seals	21
Compression Gaskets, Trim, Channels, Bumpers, and Other Non-Inflatable Profiles	22 & 23



Applications

Pawling Engineered Products specializes in the custom design and manufacture of inflatable rubber products, seals, and other engineered rubber devices. We will carefully analyze your problem, apply our extensive technical knowledge, and follow your project through to an efficient solution. Advanced compounding, molding, extruding, fabricating, coupled with testing equipment and processes enable us to address your most demanding needs for rubber fabrications that require a high level of durability and reliability.



Powder & Bulk Solids Processing Equipment:
Mixers, blenders, screeners, dryers, chutes, hoppers, valves



Transportation:
High speed trains, tailgate seals, automobile emission control test sheds

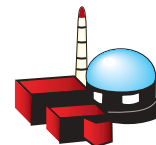

Nuclear:
Door and hatch seals, pool gate seals, refueling seals, nozzle dam seals

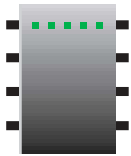

Electronic/Wafers Semiconductor Processing:
Washers, soldering equipment, furnaces, filters, load locks, measuring equipment, actuators



Medical:
Virology laboratories, clean rooms, sterilizers



Wineries:
Lid seals for variable capacity wine tanks



Paper Machinery: Seals for the wet end of paper machinery, doctor blade bladders, inflatable bladders for expanding mandrels for slitters and scorers



Aerospace/Aircraft:
Wind tunnels, jet engine test cells, bladders for bonding and clamping fixtures, door and hatch seals

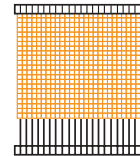

Textile Machinery:
Pressure chambers, inflatable clamps



Conveyors:
Conveyor stops, brakes, bumpers

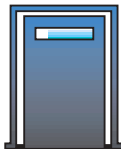

Converting Equipment:
Access way seals

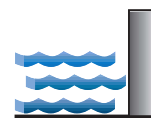

Flood Protection:
Gate and door seals



Food Processing Equipment:
Smokehouse door seals

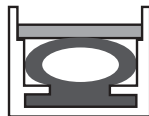

Robotics Material Handling: Clamps, grips, actuators

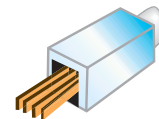

Wood Processing:
Drying kilns, log preparation chambers



Marine:
Cargo hatches, elevator platforms, maintenance or shut down seals on propeller shafts, personnel hatches



Fluid Sealing:
Isolation valve seals, follower plate seals, maintenance shutdown shaft seals

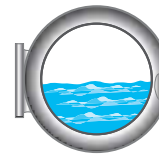

Commercial Laundry Machinery:
Door seals

Applications In Detail

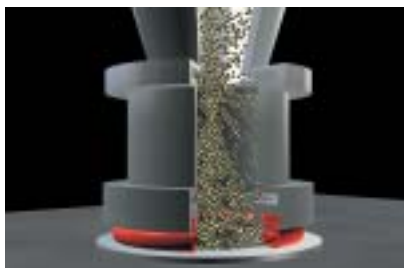

Hopper to Transfer Cart: Pneuma-Seal on the mouth of the hopper valve or metering device expands axially down to form a leak-tight seal around the fill opening in a transfer cart.



Slide Gate Valves: Pneuma-Seal provides the tightest seal possible for controlling the flow of very fine materials. The inflation and deflation of the seal is timed to coincide with the closing and opening of the slide gate.



Automobile Emission Control Test Shed Door Seals: Airtight enclosures help automotive engineers evaluate carburetor and fuel tank vent evaporative emissions. Warmed up test vehicles are pushed into hot soak enclosures. Escaping fuel vapors are measured by instruments outside the test cells. The doors to the cells are typically sealed using the Type 1 Pneuma-Seal design supplied in either EPDM (EP) or Neoprene (CR).



Airtight Doors: Airtight doors in virology laboratories, animal rooms, and decontamination areas are tightly sealed with Pneuma-Seals installed around the periphery of the door to expand radially outward. This design facilitates frequent access since there is no requirement to actuate multiple dogs and there is no raised sill to obstruct personnel and equipment traffic. Pawling's wholly-owned subsidiary, Presray, specializes in the manufacture of full airtight door assemblies. See www.fpp.presray.com for more detailed examples.

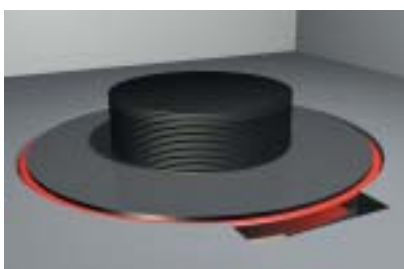

Load Lock: Pawling manufactures a unique inflatable seal made of low outgassing Butyl rubber material which has been tested for vacuum service. This design provides a highly efficient and repeatable seal in the patented vacuum load lock section of a fully automated electron beam metrology system.



Conveyor Stops/Brakes: Pneuma-Seal inflatable bladders represent two different ideal solutions to controlling and preventing jams on conveyor systems. Positioned alongside the product at the outer extremities of the conveyor belt (or rolls), they can be inflated against the product to temporarily interrupt the flow while the jam clears downstream. Alternately the bladders can be located underneath the product flow and activated to release the contact between belt and rollers, thereby interrupting flow while the jam clears.

Available in Many Configurations

Available in many configurations complete with required inflation connections, Pneuma-Seal requires no bonding or splicing by the user.

Pneuma-Seals (shown in a variety of cross sections on pages 8-14) can be configured to practically any shape or size. Our products can be supplied as continuous loops (Fig. 1), in strip form with sealed ends (Fig. 2), in "U" or similar shapes with preformed corners (Fig. 3), in endless configurations with preformed corners (Fig. 4), or complex configurations (Fig. 5). In many cases, a seal will conform to the corners or radii of a given installation without

the necessity for preforming these corners or radii into the seal. Minimum bend radius information for circular seals, or corners on rectangular seals, is available. When requesting this data, refer to the desired cross-sections (see pages 8 to 14) and the applicable plane of use as indicated (Figs. 1, 6, 7). Arrows indicate direction of inflation.

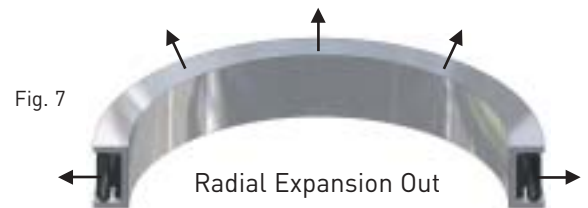
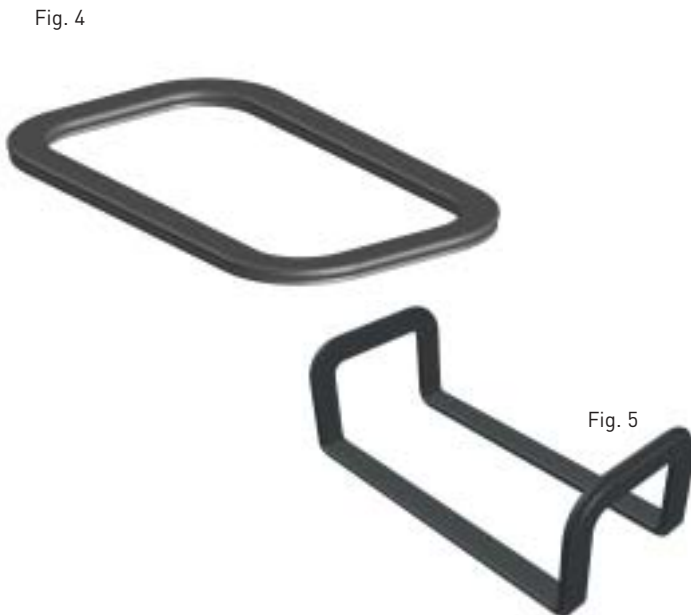

Many of the seals can be supplied with no joints, if required.

Pawling's unique facilities and processing techniques can produce seamless (no vulcanized joints) rubber products of virtually limitless length and size to your specifications (fabric-reinforced or non-reinforced).

Pneuma-Seal Materials

Pneuma-Seal is available in a wide variety of materials as noted below, although the specific elastomers vary somewhat from one profile to another. If required, cross sections can be custom made using materials other than those indicated in this manual. Please note that the ratings given to the properties of the elastomers are based on Pawling compounds as they are applied to inflatable seals. The ratings of other manufacturers may differ as the result of compounding variables and end product use. Also note that the addition of fabric reinforcing overcomes drawbacks associated with some of the relatively poor physical characteristics of silicone, fluorosilicone, fluorocarbon rubber, and nitrile.

Common Name — Base Polymer	EPDM or EP Rubber	Neoprene	Nitrile or NBR or Buna-N	Natural Rubber	Butyl	Silicone	Fluorosilicone	Fluorocarbon
Chemical Name	Ethylene Propylene	Chloroprene	Acrylonitrile Butadiene	Natural Isoprene	Isobutylene Isoprene	Silicone	Fluorosilicone	Fluorocarbon
ASTM Designation (ASTM D1418)	EP	CR	NBR	NR	IIR	VMQ	FVMQ	FKM
Tensile Strength (psi)	>2000	>2000	>2000	>2000	>2000	>1200	>1200	>1400
Hardness Range (Durometer A)	40-90	20-80	50-95	50-70	40-75	40-80	40-70	70-90
Tear Resistance	G	G	F	G	G	F	P	F
Abrasion Resistance	G to E	VG	G	E	G	P	F	G
Compression Set	G	G	G	E	F	VG	E	E
Resilience Cold	G	G	G	G	P	E	G	F
Resilience Hot	VG	VG	G	F	VG	E	E	E
Radiation Resistance	O	G	P	F to G	G	G	E	E
Impermeability to Gases	G	G	G	F	O	F	E	P
Acid Resistance								
Mild Dilute	E	E	F to G	F to P	E	E	E	O
Strong Concentrate	G	G	F to G	P	G	F	G	E
Solvent Resistance								
Aliphatic Hydrocarbons	P	F to G	E	P	P	P	G	E
Aromatic Hydrocarbons	P	P	P	P	P	P	E	E
Oxygenated (Ketones, etc)	G	P	P	P	G	P	F	F
Resistance To:								
Swelling in Lubricating Oil	P	G	VG	P	P	P	E	O
Oil and Gasoline	P	G	E	P	P	F	G	E
Animal Oils	F	F	E	P	F	G	E	E
Water Absorption	VG	G	VG	VG	VG	E	E	E
Oxidation	E	VG	G	F to P	E	E	O	G
Ozone	O	VG	F	F to P	F to G	E	O	E
Sunlight Aging	O	VG	P	F to P	VG	E	E	G
Heat Aging	VG	G	G	G to F	G	O	E	E
Low Temperature	VG	G	F to G	G	G	O	G	F
Flame	P	G	P	P	P	F	E	E
Vegetable Oils	F	G	G	P	F	P	E	E
Chlorinated Hydrocarbons	P	P	F	P	P	P to F	F	G

O = Outstanding E = Excellent VG = Very Good G = Good F = Fair P = Poor

Type 1

The “original” Pneuma-Seal and most popular inflatable profile. These cross sections are designed for ease of mechanical retention (see page 9 for options) and the “foot” allows the bulb portion to expand fully, thereby ensuring full gap optimization.

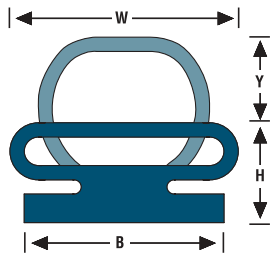

Type	Materials	W	H	B	Y	Y	Standard air connections (See pages 18 & 19)
Non-Reinforced							
PRS573	EP, CR, VMQ	11/16	7/16	11/16	1/8	1/16	1A, 1B, 10, 11, 12
PRS978	EP	1	1/2	3/4	1/4	3/16	1A, 1B, 10, 11, 12
PRS537	EP, CR, NBR, VMQ, FKM	1 1/4	5/8	1	3/8	1/4	1A, 1B, 10, 11, 12
PRS535	EP, CR, NBR, VMQ	2	7/8	1 3/4	3/4	3/8	1C, 1D, 4A, 4B, 10, 11, 12
PRS548	EP, CR	3	1 1/4	2	1	1/2	1C, 1D, 4A, 4B, 10, 11, 12
PR28925	EP	3 1/4	1 1/4	2	1 1/8	5/8	1C, 1D, 4A, 4B, 10, 11, 12
PRS934	CR	4	1 5/8	3	1 3/8	7/8	1C, 1D, 4A, 4B, 6, 8, 10, 11, 12
Reinforced							
PR13548	EP	11/16	7/16	11/16	1/8	1/16	2
PRS717	EP, VMQ	1	1/2	3/4	5/16	3/16	2
PRS580	EP, CR, NBR, VMQ	1 1/4	5/8	1	3/8	1/4	2
PRS582	EP, CR, NBR, VMQ	2	7/8	1 3/4	3/4	1/2	3A, 3B
PRS583	EP, CR, VMQ	3	1 1/4	2	1 1/4	3/4	3A, 3B
PRS705	EP	4	1 5/8	3	1 3/4	1 1/4	3A, 3B
PRS729	EP	5 1/2	1 5/8	4	2 1/4	1 5/8	3A, 3B
PRS590	EP	7 1/4	2 1/16	4 1/8	3	2	3A, 3B



Type	Materials	W	H	B	Y	Y	Standard air connections (See pages 18 & 19)
Non-Reinforced							
PRS951	EP, VMQ	1 3/16	7/8	1 13/16	5/16	3/16	10, 11, 12
PR9185	EP, VMQ	1 9/16	1	1 9/16	1/2	5/16	10, 11, 12
PRS946	EP	2 3/8	1 3/8	2 3/8	13/16	7/16	10, 11, 12
PRS974	EP	3 1/2	2 3/16	3 1/2	1 1/8	5/8	10, 11, 12
Reinforced							
PRS584	EP	4	1	3 1/4	2	1 1/4	3A, 3B

Material availability is indicated by cross section. Please refer to page 7 for material identification. If required, cross sections can be custom made using materials other than those indicated.

Retention System for Type 1 Profiles



Figure A

Passivated steel, stainless steel or aluminum clips tack welded or screwed to a flat surface. Seal is "snaked" between clips.

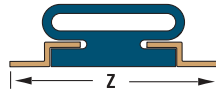

Figure B

Bar size, structural, extruded, or fabricated steel, stainless steel or aluminum channel with pins screwed into tapped holes in the flanges. Seal is "snaked" between pins.

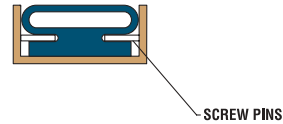

Figure C

Extruded or fabricated stainless steel or aluminum shapes - one permanently welded or screwed in place; one movable to facilitate seal installation.

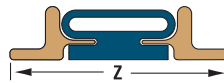

Figure D

Extruded aluminum retainer for strip seals. Seal is fed into retainer from one end.

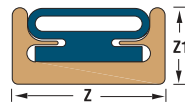

Figure E

Extruded aluminum retainer for strip seals. Seal is fed into retainer from one end.

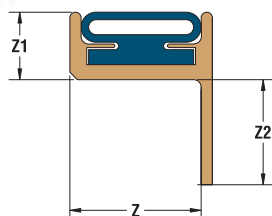

Figure A Retainer

Seal Type	Z	Retainer Clip
PRS573	1 9/16	PRS874
PRS717, PRS978	1 3/4	PRS487
PRS580, PRS537	2	PRS487
PRS582, PRS535	3	PRS488
PRS583, PRS548	3 3/8	PRS489
PRS584	4 1/2	PRS489
PRS705	4 7/8	PRS818
PRS590	5 1/8	PR14479
PRS729	7 1/2	PR9981

Recommended Spacing (Fig. A & B)

Seal Type	X	Seal Type	X
PRS573, PR13548	4"	PRS535, 582	10"
PRS978, PRS717	5"	PRS548, 583	15"
PRS537, 580	6"	PRS705, 584	20"

Figure C Retainer

Seal Type	Z	Retainer
PRS717, PRS978	2 1/2	PR12434
PRS580, PRS537	3 1/8	PRS9494
PRS582, PRS535	3 3/4	PR5710
PRS583, PRS548	4 3/8 - 4 5/8	PR5223-PR9158
PRS705	5 3/4	PR5224
PRS584	5 7/8	PR6800
PRS729	7 3/4	PR23255
PRS590	9 1/2	PR23212

Figure D Retainer

Seal Type	Z	Z1	Retainer
PRS717, PRS978	1 1/4	21/32	PR12379
PRS580, PRS537	1 9/16	13/16	PR4009
PRS582, PRS535	2 1/2	1 1/4	PR5690
PRS583, PRS548	3 5/8	1 9/16	PR6491

Figure E Retainer

Seal Type	Z	Z1	Z2	Retainer
PRS573, PR13548	1	19/32	7/8	PR13506
PRS582, PRS535	2 3/8	1 1/8	1 3/4	PR5802
PRS583, PRS548	3 5/8	1 9/16	1 3/4	PR12391

Type 2

Designed primarily for endless radial expansion inward or outward where the seal can be snap fit into a retention channel.

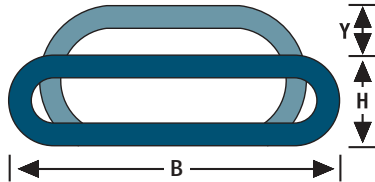

Type	Materials	B	H	Y	Max Gap for low differential pressure (side load)	Max Gap for high differential pressure (side load)	Standard air connections (See pages 18 & 19)
Non-Reinforced							
PRS920	EP, VMQ	3/4	1/4	3/16	1/8	1A, 1B, 5, 10, 11, 12	
PRS904	NR	7/8	5/16	3/16	1/8	1A, 1B, 5, 10, 11, 12	
PRS903	EP	1 1/4	3/8	3/8	1/4	1A, 1B, 4A, 4B, 10, 11, 12	
PRS509	VMQ	1 1/2	3/8	3/8	N/A	1A, 1B, 4A, 4B, 10, 11, 12	
PRS525	CR	1 1/2	1/2	7/16	1/4	1A, 1B, 4A, 4B, 5, 7, 10, 11, 12	
PRS423	EP, CR	2	1/2	3/4	3/8	1A, 1B, 4A, 4B, 5, 6, 7, 10, 11, 12	
PRS564	EP	2 1/2	1/2	7/8	3/8	1A, 1B, 4A, 4B, 5, 6, 7, 10, 11, 12	
PRS520	CR	3	3/4	1	1/2	1A, 1B, 4A, 4B, 5, 6, 7, 10, 11, 12	
PRS578	EP	3 1/4	1/2	1	1/2	1A, 1B, 4A, 4B, 5, 6, 7, 10, 11, 12	
PR10287	EP	5 5/8	1 1/4	1 3/4	N/A	4A, 4B, 6, 7, 10, 11, 12	
PR17559	EP	6	3/4	2	N/A	4A, 4B, 6, 7, 10, 11, 12	
PR11011	EP	7 3/8	1 1/4	2 1/2	N/A	4A, 4B, 6, 7, 10, 11, 12	
Reinforced							
PR29752	EP	3/4	1/4	1/8	1/16	2	
PRS733	EP, CR	3/4	3/8	1/8	1/16	2	
PRS701	EP, CR, VMQ	1 1/4	3/8	3/8	1/4	2	
PRS702	EP, CR, VMQ	2	1/2	3/4	1/2	3A, 3B	
PRS703	EP	3	3/4	1 1/4	3/4	3A, 3B	
PRS706	EP	4	1	1 3/4	1 1/4	3A, 3B	
PRS512	EP	6	1 1/2	2 1/2	1 3/4	3A, 3B	

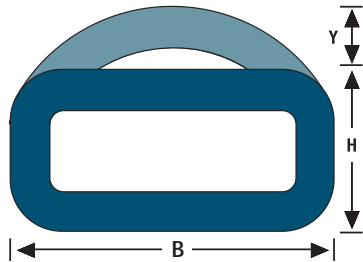

Type	Materials	B	H	Y	Max Gap for low differential pressure (side load)	Max Gap for high differential pressure (side load)	Standard air connections (See pages 18 & 19)
Non-Reinforced							
PRS900	EP, CR	13/32	3/16	3/32	1/16	1A, 1B, 10, 11, 12	
PR28501	EP	17/32	5/32	3/32	1/16	1A, 1B, 10, 11, 12	
PR10487	EP	1/2	5/16	3/32	1/16	1A, 1B, 10, 11, 12	
PRS924	CR	3/4	1/4	3/16	1/8	1A, 1B, 10, 11, 12	
PRS554	EP, CR	3/4	3/8	3/16	1/8	1A, 1B, 5, 10, 11, 12	
PRS102	EP, CR	15/16	5/16	3/16	1/8	1A, 1B, 5, 10, 11, 12	
PRS577	EP	15/16	1/2	1/4	3/16	1A, 1B, 5, 10, 11, 12	
PRS905	CR	1 1/2	3/4	1/2	3/8	1A, 1B, 4A, 4B, 5, 10, 11, 12	
PRS571	CR	1 5/8	1/4	7/16	1/4	1A, 1B, 10, 11, 12	

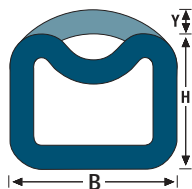

Type	Materials	B	H	Y	Max Gap for low differential pressure (side load)	Max Gap for high differential pressure (side load)	Standard air connections (See pages 18 & 19)
Non-Reinforced							
PRS907	CR	1/2	1/2	1/16	1/16	1A, 1B, 10, 11, 12	
PR4982	EP, VMQ	5/8	17/32	3/16	1/8	1A, 1B, 10, 11, 12	
PRS440	CR	3/4	3/4	1/8	1/16	1A, 1B, 10, 11, 12	
PR14888	CR	25/32	7/8	1/4	1/8	1A, 1B, 10, 11, 12	
PRS526	CR	7/8	7/8	1/4	1/8	1A, 1B, 10, 11, 12	

Retention Systems

Adhesives are required if used in configurations other than radially expanding inward/outward. Note, however, that adhesives are significantly less reliable than the mechanical retention systems used with Type 1 or 3 seals. For recommended retainer groove (gland) dimensions please refer to page 13.

Type 3

The classic Pneuma-Seal profile, These cross sections are designed specifically for a snap fit into a mating dovetail groove. The Type 3 convoluted design, along with the Type 4, also provides the greatest gap/width coverage when compared to other designs.

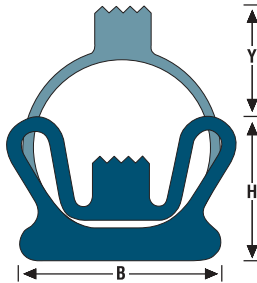

Type	Materials	B	H	Y*	Standard air connections (See page 18)
Reinforced					
PRS599	EP, VMQ	5/8	1/2	3/8	2
PRS591	EP, VMQ	11/16	1/2	7/16	2
PR14575	EP	7/8	1/2	7/16	2
PRS581	EP, CR, NBR, VMQ	7/8	5/8	1/2	2
PRS594	EP, NBR	1 3/4	1 7/32	1 7/32	3A
PRS722	EP	3	2 1/8	2	3A
*Recommended Maximum Gap					

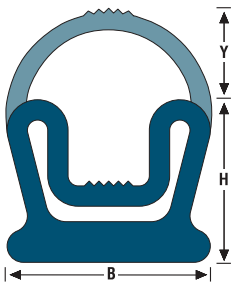

Type	Materials	B	H	Y*	Standard air connections (See page 18)
Reinforced					
PRS592	EP	5/8	1/2	1/4	2
PRS595	EP	7/8	1/2	3/8	2
*Recommended Maximum Gap					

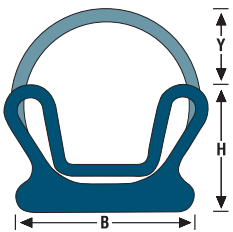

Type	Materials	B	H	Y*	Standard air connections (See page 18)
Reinforced					
PRS598	EP, VMQ	11/16	1/2	1/4	2
PRS597	EP, VMQ	7/8	5/8	3/8	2
PRS708	EP, NBR	1 3/4	1 7/32	13/16	3A
*Recommended Maximum Gap					

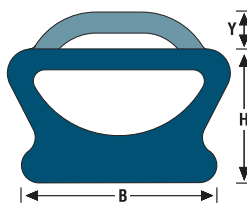

Type	Materials	B	H	Y*	Standard air connections (See page 18)
Non-Reinforced					
PRS980	VMQ	5/8	17/32	3/32	1A, 1B, 11
PRS902	EP	7/8	1/2	1/4	1A, 1B, 5
PRS916	EP	1 3/4	1 15/32	5/8	1A, 1B, 4A, 4AB, 7
Reinforced					
PRS709	EP	7/8	5/8	5/16	3A
*Recommended Maximum Gap					

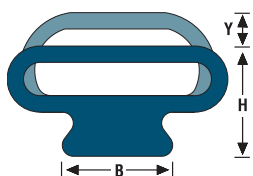

Type	Materials	B	H	Y*	Standard air connections (See page 18)
Non-Reinforced					
PRS736	EP	5/8	1 1/4	5/8	3/8
*Recommended Maximum Gap					

Material availability is indicated by cross section. Please refer to page 7 for material identification. If required, cross sections can be custom made using materials other than those indicated.

Retention Systems for Type 3 Profiles

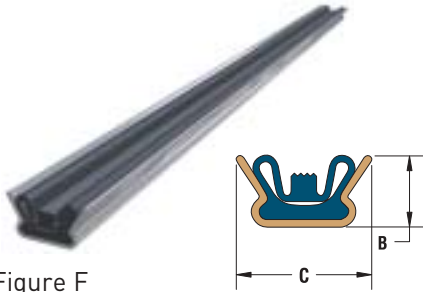

Figure F

Extruded aluminum retainer (available from Pawling). Seal "snaps" in place.



Figure G

Machined groove. Seal "snaps" in place.



Figure H

Extruded synthetic rubber retainer (available from Pawling) rigidly supported on sides. Seal "snaps" in place.

Figure F Retainer			
Seal	B	C	Retainer No.
PRS592, PRS599	19/32	7/8	PR3593
PRS591	19/32	1	PR3592
PRS581, PRS597	11/16	1 1/4	PR3406
PRS594, PRS708	1 1/4	2 1/2	PR4226

Consult Pawling for dimensions

Figure H Retainer			
Seal	B	C	Retainer No.
PRS595, PR14575	5/8	1 1/4	PR3859
PRS581, PRS597	7/8	1 1/2	PR3073
PRS594	1 5/8	3	PR13161

Type 4

Similar to the Type 3, the Type 4 Pneuma-Seal is designed for large gap coverage along with ease of retention within a square channel.

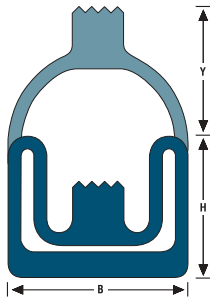

Type	Materials	B	H	Y*	Standard air connections (See page 18)
Reinforced					
PRS715	EP, NBR	17/32	7/16	3/8	2
PRS707	EP, VMQ	21/32	7/16	7/16	2
PR11903	EP	7/8	5/8	1/4	2
PRS713	EP	1 3/4	1 3/8	1 1/4	3A
*Recommended Maximum Gap					

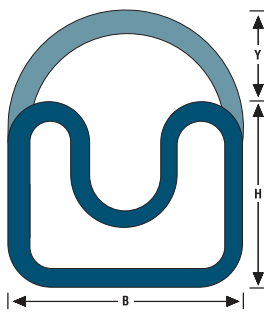

Type	Materials	B	H	Y*	Standard air connections (See page 18)
Non-Reinforced					
PRS911	EP	19/32	3/8	1/8	1A, 1B
PR29416	EP	11/16	5/8	1/4	1A, 1B
PR6648	EP	15/16	3/4	3/8	1A, 1B
PR27880	EP	2 1/2	1 31/32	1	1C, 1D, 4A, 4B
Reinforced					
PR14179	EP	9/16	7/16	5/32	1A, 1B
PR12854	EP	19/32	3/8	5/32	2
PR11980	EP	5/8	9/16	9/32	2
PRS732	EP	15/16	3/4	13/32	2
PRS740	EP	1 11/32	1 1/16	1/2	3A
*Recommended Maximum Gap					

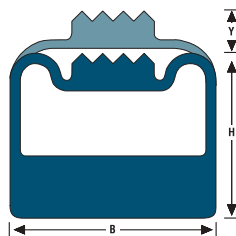

Type	Materials	B	H	Y*	Standard air connections (See page 18)
Reinforced					
PR8087	VMQ	5/8	1/2	1/8	1A, 1B
*Recommended Maximum Gap					

Type 10

Designed primarily for high pressure, low gap applications. When inflated, the sidewalls elongate to cover the necessary gap.

Type 10A (Squared Sealing Beads)

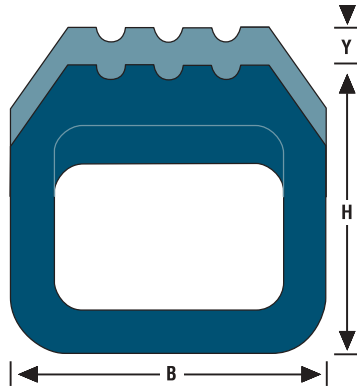

Type	Materials	B	H	Y	Standard air connections*
Non-Reinforced					
PR15092	EP, VMQ, FKM	.551 (14)	.394 (10)	.118 (3)	10, 11, 12, 13
PRS945	EP, VMQ	.551 (14)	.453 (11.5)	.118 (3)	10, 11, 12, 13
PRS950	EP, VMQ, FKM	.630 (16)	.472 (12)	.118 (3)	10, 11, 12, 13
PRS960	EP, VMQ	.630 (16)	.709 (18)	.138 (3.5)	10, 11, 12, 13
PRS955	EP, VMQ	.866 (22)	.748 (19)	.138 (3.5)	10, 11, 12, 13
PRS952	EP, VMQ	1.024 (26)	.748 (19)	.178 (4.5)	10, 11, 12, 13
PRS949	VMQ	1.063 (27)	.827 (21)	.197 (5)	10, 11, 12, 13
PRS966	VMQ	1.181 (30)	.630 (16)	.197 (5)	10, 11, 12, 13
PRS972	EP, VMQ	1.378 (35)	1.024 (26)	.315 (8)	10, 11, 12, 13
PR6119	EP, VMQ	1.378 (35)	1.260 (32)	.394 (10)	10, 11, 12, 13

*Flexible connections terminating with 1/8 NPT fittings are also available.

Type 10B (Angled Sealing Beads)

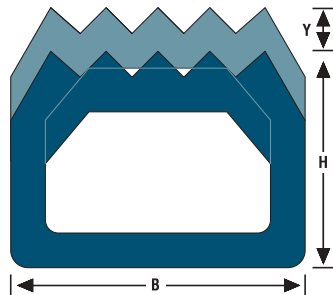

Type	Materials	B	H	Y	Standard air connections*
Non-Reinforced					
PRS973	EP, VMQ	.256 (6.5)	.197 (5)	.059 (1.5)	10, 11, 12, 13
PRS977	VMQ	.394 (10)	.315 (8)	.078 (2)	10, 11, 12, 13
PRS971	EP, VMQ	.630 (16)	.551 (14)	.138 (3.5)	10, 11, 12, 13
PRS969	EP, VMQ	.787 (20)	.787 (20)	.157 (4)	10, 11, 12, 13
PRS970	EP, VMQ	.827 (21)	.945 (24)	.197 (5)	10, 11, 12, 13
PRS942	VMQ	2.126 (54)	1.575 (40)	.315 (8)	10, 11, 12, 13

*Flexible connections terminating with 1/8 NPT fittings are also available.

Recommended Retainer Groove for Types 2, 4, 10A & 10B Pneuma-Seals

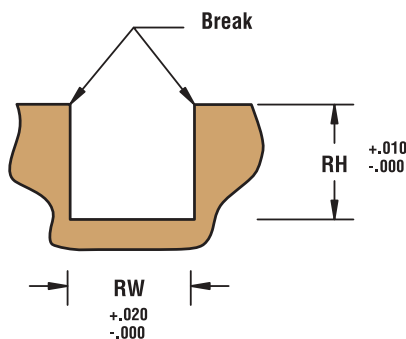

RW = seal profile width (w dimension) with its plus tolerance

RH = seal profile height (H dimension) with its plus tolerance

Surface finish of bottom of machined groove should be 63 microinch or better with finish lay parallel to seal.

For circular, radial expansion inward/outward configurations, especially smaller diameters, seals are sized so that their tension or compression forces are generally sufficient to hold them in place. If used in other configurations, adhesives are generally required.

Type 7

Designed to provide large surface contact for lifting applications, but can also be used as seals. Standard aluminum channel sizes may be used with Type 7's (see below).

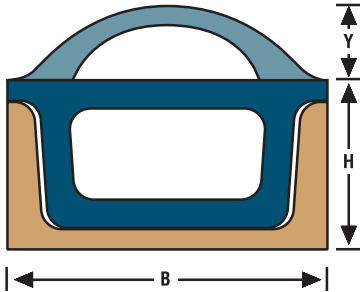

Type	Materials	B	H	Y*	(Steel or Alum.) T	Standard air connections (See page 18)
Non-Reinforced						
PRS576	CR	2	15/16	1/2	.125	1A, 1B, 4A, 4B, 6, 7
PRS505	CR	3	1 7/16	3/4	.170, .258, .356	1A, 1B, 4A, 4B, 6, 7
PRS436	CR	4	1 3/4	1	.184, .247, .321	1A, 1B, 4A, 4B, 6, 7
PRS501	CR	5	1 15/16	1 1/2	.190, .325	1A, 1B, 4A, 4B, 6, 7

*Recommended Maximum Gap

Other Pneuma-Seal Types

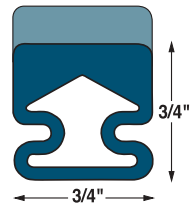

PR22359 (VMQ)

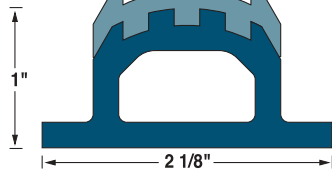

PR28429 (VMQ)

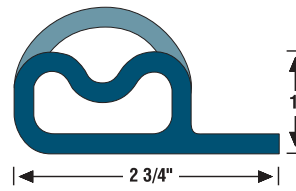

PRS533 (NR)

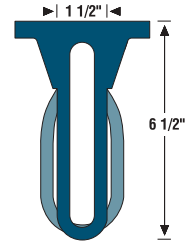

PRS585 (EP)

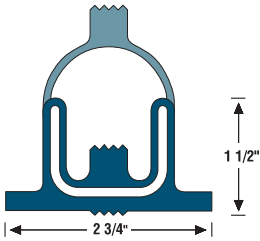

PRS714 (EP)

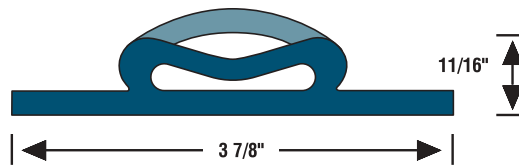

PRS917 (CR)

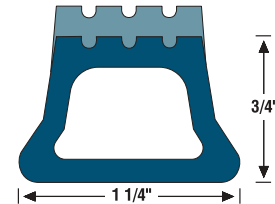

PRS947 (EP)

Sealing Small Diameters

When the OD or ID of the surface to be sealed is too small for a standard Pneuma-Seal cross section, inflatable "bladders" are employed (PR16376 and PR16436 below). This concept is generally used for seals less than 2" in diameter, but may be used for seals up to 6" or more in diameter. Typically, Pawling supplies the molded bladders and the required dimensions for the user supplied 3-piece housings, but on request, Pawling will also furnish the housings.



PR 16376



PR 16436

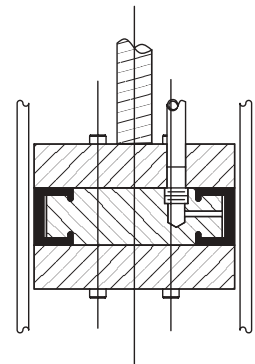

2-Piece Seals

When excessively high pressure differentials and/or harsh environmental conditions are present, 2-piece seals can be utilized. The solid elastomeric sealing pad isolates and protects the inflatable actuator tube.

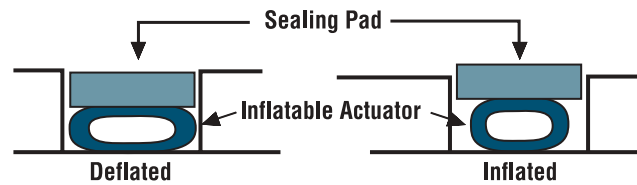

Mechanical Interlocking Seal Ends

For installations where the inflatable seal must be wrapped around a shaft or other cylindrical surface, and cannot be installed over the end, mechanical interlocking male-female molded seal ends can be incorporated. (This option is only available in limited seal types — consult Pawling.)



End Configurations for Types 1 & 2 Seals

In the ends of Type 1 and Type 2 seals there is a solid non-expanding portion at the extreme end followed by a transition area where the expansion gradually increases until it reaches the full sealing position, as shown in the illustration below.



Standard Boot End Dimensions

SEAL	A 1*	B 1*	C	D	E
PRS573	7/8	2 3/8	7/16	7/16	11/16
PRS537	1 1/8	1 7/8	3/4	5/8	1
PRS535	1 3/16	2 1/4	11/16	7/8	1 5/8
PRS548	1 11/16	3 1/4	1 3/16	1 1/4	2 1/4
PRS717	7/8	2 3/8	1/2	1/2	13/16
PRS580	1 1/8	3 1/8	5/8	5/8	1
PRS582	1 1/2	3 1/2	1	7/8	1 5/8
PRS583	2 1/4	4 1/8	1 3/4	1 1/4	2 1/2
PRS705	2 3/8	4 1/8	1 7/8	1 5/8	3 3/8
PRS729	3 1/2	5	3	1 5/8	3 1/4
PRS590	5 1/2	9 1/2	4 3/4	2 1/16	4 1/16
PRS584	2 3/8	4	1 7/8	1	3

NOTES:

- 1*. "A" Denotes - standard end, "B" Denotes - extended end
2. Dimensions on "A", "B" & "C" are approximate to within 3/32.
3. "D" dimension equals deflated height of seal. "E" dimension equals maximum inflation height indicated on page 8.

Strip seals should be securely clamped as illustrated below. For clamp dimensions, consult Pawling.

Figure 1



Figure 2



Figure 3



Figure 4



End Configurations for Type 3 Seals

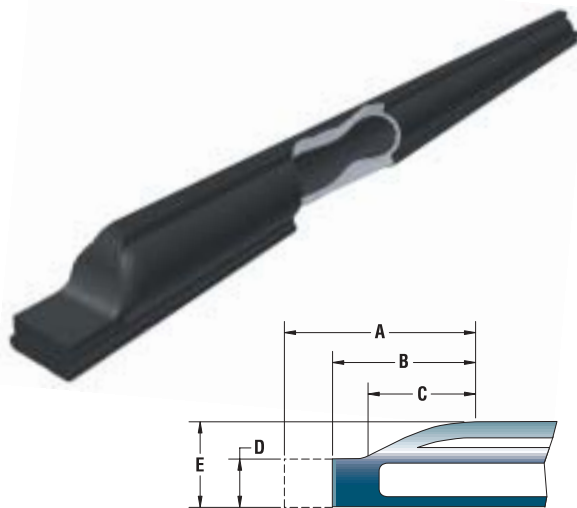

Standard Boot End Dimensions

SEAL	A *	B *	C	D	E
PRS599	2 1/4	1 1/2	1 1/8	1/2	3/4
PRS591	2 1/4	1 1/2	1 1/8	1/2	15/16
PR14575	2 1/4	1 1/2	1 1/8	1/2	7/8
PRS581	2 1/4	1 5/8	1 1/4	5/8	1 1/8
PRS594	3 1/2	2	1 1/2	1 7/32	2 7/16
PRS722	3 1/2	2 3/4	2	2 1/8	4 1/8

NOTES:

- 1*. "A" Denotes - extended end. "B" Denotes - standard end.
2. Dimensions on "A", "B" & "C" are approximate to within 3/32.
3. "D" dimension equals deflated height of seal. "E" dimension equals maximum inflation height indicated on page 11.

End Configurations & Clamps for Types 10A and 10B Profiles

Types 10A and 10B seals are available with two different sealed end heights, low and high. The low ends are sealed at a height approximately 10% higher than the relaxed hollow profile and the high ends sealed at a height approximately 20% higher than the relaxed hollow profile.



Side View Of Sealed End

Type 10A	H (mm)	LE (low end)	HE (high end)	L (solid)	Type 10B	H (mm)	LE (low end)	HE (high end)	L (solid)
PR15092	.394 (10)	.433 (11)	.512 (13)	.551 (14)	PRS973	.197 (5)	.217 (5.5)	.256 (6.5)	.256 (6.5)
PRS945	.453 (11.5)	N/A	N/A	N/A	PRS977	.315 (8)	N/A	N/A	N/A
PRS950	.472 (12)	.512 (13)	.591 (15)	.630 (16)	PRS969	.787 (20)	.847 (21.5)	.945 (24)	.787 (20)
PRS960	.709 (18)	.768 (19.5)	.847 (21.5)	.630 (16)	PRS970	.945 (24)	1.024 (26)	1.142 (29)	.827 (21)
PRS955	.748 (19)	.807 (20.5)	.866 (22.5)	.866 (22)	PRS942	1.575 (40)	1.654 (42)	1.890 (48)	2.126 (54)
PRS952	.747 (19)	.807 (20.5)	.925 (23.5)	1.024 (26)					
PRS949	.827 (21)	.906 (23)	1.024 (26)	1.063 (27)					
PRS966	.630 (16)	N/A	N/A	N/A					
PRS972	1.024 (26)	1.142 (29)	1.339 (34)	1.378 (35)					
PR6119	1.260 (32)	1.378 (35)	1.772 (45)	1.378 (35)					

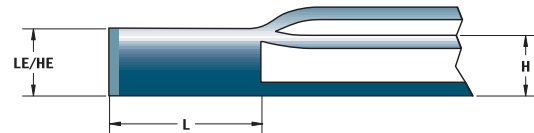

Ends of strip seals should be securely clamped as illustrated below.



Corner Configurations

As a general rule Pneuma-Seal, molded or extruded, is flexible enough in a radial seal application (Fig. 1) to conform to a corner radius of between four and eight times its relaxed height, depending on the specific profile. However, the expansion in these corners will always be at least partially restricted unless the radius is even more liberal than this. The effect is more severe when the seal is positioned for radial expansion inward than when positioned for radial expansion outward. Therefore, when the designer has a choice, the latter location is preferable. Square right angle corners are not available for seals which expand radially inward or radially outward. However, if the requirement is to seal a rectangular opening with a radially outward expanding seal, a special design as described below (Fig. 4 & 5) can be furnished. In axially expanding (face)

applications, corners of rectangular non-reinforced Pneuma-Seal (Fig. 2) can be preformed to minimum centerline radii approximately twice the cross section width. (Consult Pawling for exact dimensions.)

When using molded fabric-reinforced Pneuma-Seal, designers are cautioned to consult with Pawling to avail themselves of existing corner molds.

Square right angle corners (Fig. 3) can be furnished for some axially expanding (face) applications. However, the working "gap" may, in some cases, be reduced from the figures shown in the brochure. (Consult Pawling for specifics.)

Figure 1



Figure 2



Figure 3

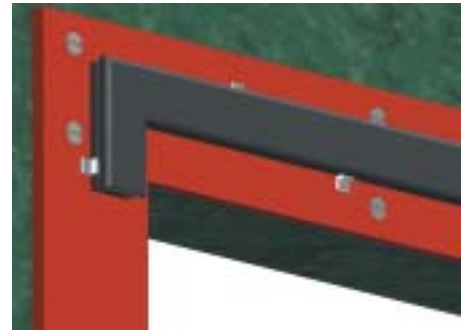

Sealing Rectangular Openings with Radially Outward Expanding Seal

Since square right angle corners are not available on radially expanding Pneuma-Seals, intermediate sealing pads are employed between the radiused seal and the square corners of the opening to be sealed. These pads can be bonded to the seal (Fig. 4) or to the corners of the opening (Fig. 5). Where possible, Figure 5 is recommended in lieu of Figure 4.

Figure 4

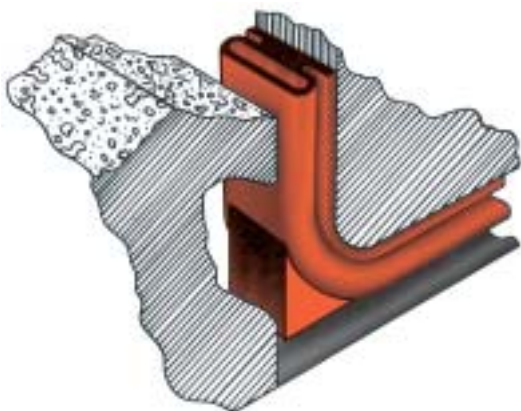
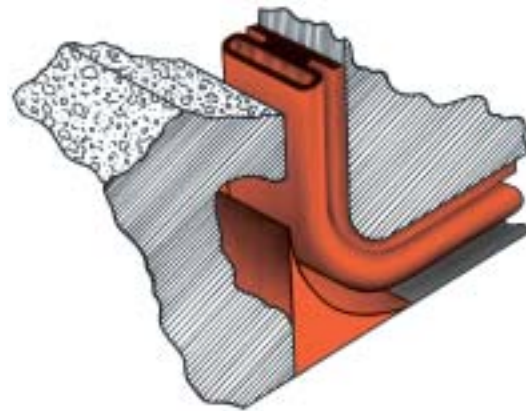

Figure 5



Air Connections for Types 1, 2, 3, 4 & 7 Pneuma-Seals

For endless seals, the standard location for the air connection is on the underside that mates with the mounting surface. For seals with closed solid ends, the air connection can either be on the underside or extending out of one end. For some Types 2, 3 and 4 profiles a third location, in the sidewall, is available (consult Pawling for feasibility). The tables on pages 8, 10, 11, 12, 13 and, 14 define which air connections are available for each profile. Some of the air connections are more resistant to abusive handling than others. In these cases, consult Pawling for air connection selection.

	<p>Type AC1A, AC1C</p> <p>1/8" I.D. Flexible tube (non-reinforced). Same material as Seal.</p> <p>1/8"-27 NPT connector with barbed end supplied as a loose item — barbed end is inserted in tube after tube is passed through clearance hole.</p>	<p>Type AC1B, AC1C</p> <p>1/8" I.D. Flexible tube (non-reinforced). Same material as Seal.</p> <p>Tire valve core connector with barbed end supplied as a loose item — barbed end is inserted in tube after tube is passed through clearance hole.</p>	<p>Type 1A: 9/32" diameter clearance hole required (break edge or counter sink).</p> <p>Type 1B: 9/32" diameter clearance hole required (break edge or counter sink).</p> <p>Type 1C: 11/32" diameter clearance hole required (break edge or counter sink).</p> <p>Type 1D: 11/32" diameter clearance hole required (break edge or counter sink).</p>
	<p>Type AC2</p> <p>Crimped Ferrule 3/8" O.D.</p> <p>3/16" I.D. x 3/8" O.D. Reinforced Hose</p> <p>1/8"-27 NPT connector with barbed end supplied as a loose item — barbed end is inserted in tube after tube is passed through clearance hole.</p>	<p>Type AC3A</p> <p>Crimped Ferrule .48" O.D.</p> <p>1/4" I.D. x .47" O.D. Reinforced Hose</p> <p>1/8"-27 NPT Connector</p>	<p>Type AC3B</p> <p>1/8"-27 NPT Connector</p> <p>1/4" I.D. x .47" O.D. Reinforced Hose</p> <p>1/8"-27 NPT Connector</p>
<p>13/32" diameter clearance hole required. Crimped Ferrule is not included on some silicone seals.</p>	<p>1/2" diameter clearance hole required. Crimped Ferrule is not included on some silicone seals.</p>	<p>19/32" diameter clearance hole required.</p>	
	<p>Type AC4A</p> <p>1/8"-27 NPT Straight Thread</p> <p>Wrench Flats</p> <p>1/8"-27 NPT Tapered Thread</p>	<p>Type AC4B</p> <p>Clamped in Base with Crimped Ferrule .48" O.D.</p> <p>1/4" I.D. x .47" O.D. Reinforced Hose</p> <p>1/8"-27 NPT Connector</p>	<p>Type 5</p> <p>Contains "Tire" Valve Core (Material: Brass or Nickel Plated Brass)</p> <p>1 5/16" Ref.</p> <p>.302-32 Thread</p>
<p>7/16" diameter clearance hole with 31/32" diameter x 5/16" deep counterbore for nut and washer or 31/32" diameter clearance for entire assembly.</p>	<p>1/2" diameter clearance hole with 31/32" diameter x 5/16" deep counterbore for nut and washer or 31/32" diameter clearance for entire assembly.</p>	<p>For seals requiring automotive type valve cores. 5/16" diameter clearance hole with 5/8" diameter x 7/32" deep counterbore for nut and washer or 5/8" diameter clearance for entire assembly.</p>	
<p>Type AC6</p> <p>Vulcanized Valve Stem 1/8"-27 NPT</p> <p>1" Min.</p>	<p>Type AC7</p> <p>Vulcanized Valve Stem 1/8"-27 NPT</p> <p>1-1/4"</p>	<p>Type AC8</p> <p>Vulcanized Valve Stem .302-32 Thread contains tire valve core.</p> <p>1-7/16"</p>	<p>Type AC9</p> <p>Metal Valve Stem (Brass or Stainless Steel) with integral O-Ring seal.</p> <p>3/4" Min.</p>
<p>3/4" diameter clearance hole with 150° countersink x 2" diameter.</p>	<p>5/8" diameter clearance hole with 150° countersink x 1-1/2" diameter.</p>	<p>3/8" diameter clearance hole with 150° countersink x 3/4" diameter.</p>	<p>Various diameters and lengths available for press fit into bored hole.</p>

End Connections for Types 1, 2, 3, 4 and 7 Pneuma-Seals

Figure A



Figure B

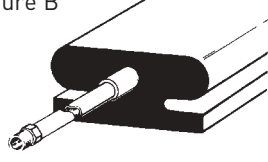
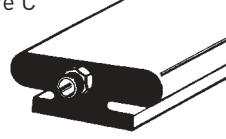

Figure C



Types AC1A, AC1B, AC2 and AC2A air connections can be located in the ends of applicable sections, as illustrated. Threaded pipe connections, as illustrated in Figure C, can also be furnished molded in place.

Air Connections for Types 10A and 10B Pneuma-Seals

For endless seals the standard location for the air connection is on the underside that mates with the mounting surface. For seals with closed solid ends the air connection can either be on the underside or extending out of one end. For some profiles, the air connection can be molded to the sidewall. If desired, please consult Pawling for design feasibility. The tables on page 13 define which air connections are available for each profile.

Type AC10

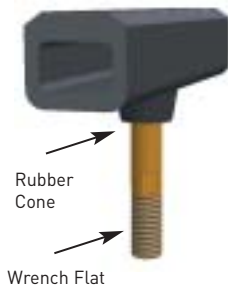

Type AC11



Type AC12

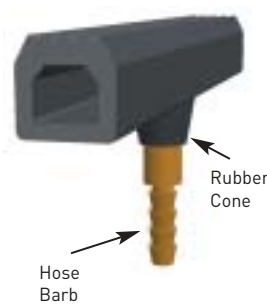

Type AC13



Type AC10



Type AC11



Type AC12



Type AC13



The illustrated Types 10, 11, 12 and 13 air connections are readily available in brass in practically any desired length within a tolerance of ± 5 mm (± 0.197 "). Exact lengths can be supplied on special order for an extra charge. Stainless steel can also be supplied instead of brass for an extra charge.

Dimensions A, B and C are both the cone dimensions and the machining dimensions for the cone countersink.

Dimensions of rubber cones are as follows:

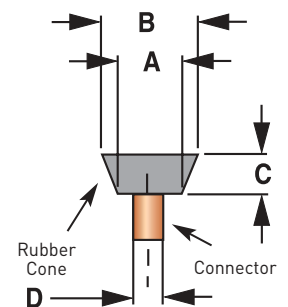

Type 10 Thread Size	Type 11 Fits Bore Sizes	Type 12 Fits Hose ID's	Type 13 Air Connector OD
M4, M6, M8, M10, M12, M16, 1/8 NPT, 1/8 BSP, 1/4 NPT, 1/4 BSP	6mm, 8mm, 10mm, 12mm	4mm, 6mm, 8mm, 10mm, 12mm, 3/16", 1/4"	4mm, 6mm, 8mm 10mm, 12mm 14mm, 16mm

D	4	4	6	8	10 or 1/8 NPT/BSP	12	14 or 1/4 NPT/BSP	16
A	5	6	10	12	14	16	18	20
B	6	8	12	14	21	24	26	28
C	3	4	6	6	10	10	12	12

Custom Rubber Fabrications

For many years, Pawling has manufactured custom products for highly unique applications. These custom rubber fabrications can be supplied in a variety of elastomeric and reinforcing materials to suit many unique requirements. Several examples are illustrated below:



A low temperature silicone seal with integral heating cable to preserve the seal's integrity under very cold conditions (-60°F).



A unique profile manufactured with cover and liner of dissimilar properties to maximize its life in difficult environments.

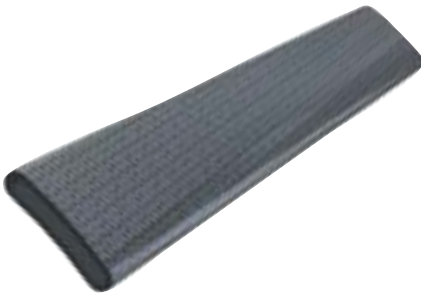

An inflatable seal with RFI-EMI shielding.

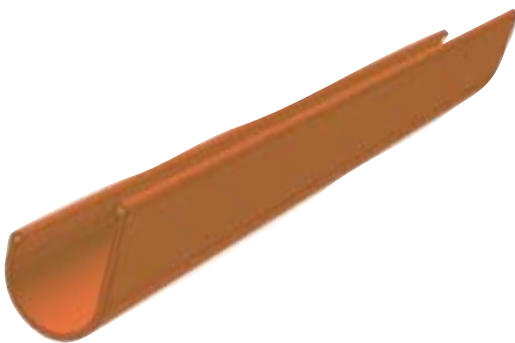

A large multi-layer fabric reinforced expansion joint used to seal large gaps and withstand seismic movement.



Inflatable pads for lifting or applying uniform clamping or bonding pressure.

Special Custom Molded Cross Sections

These designs are primarily used where tight, molded tolerances are needed or where the elastomer is difficult to extrude. Typical applications include large O-rings or rectangular seals for flood gates or dams; soft durometer (25 duro), longer lasting dense compression seals to be used in lieu of sponge; seals requiring use of a very low compression set EPDM (see Pawling for details); and seals manufactured of Fluoroelastomer (FKM).



PR30290



PR8400

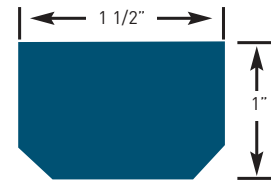

PRS 1200

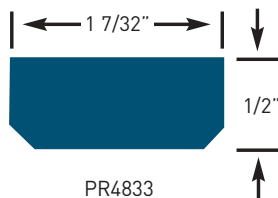

PR4833

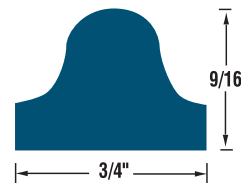

PRS933

Molded Fabric Cross Sections

In some instances, fabric is required to either improve a gasket's strength or lower the coefficient of friction on its surface. Because they cannot be extruded, a special compression molding process is required. The cross sections below are several examples of what is available. Typical applications include aircraft canopy seals, Navy ship deck lip seals, and low friction shaft seals.

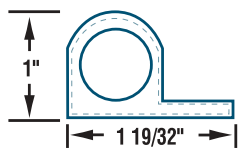

PR10938

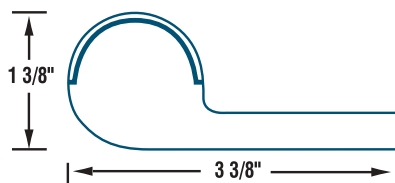

PR28470

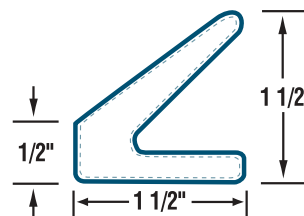

PR11653

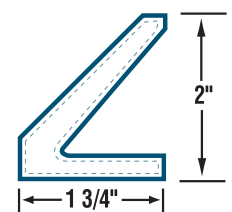

PR16632

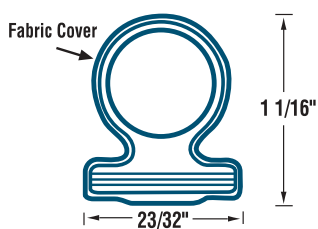

PR10063

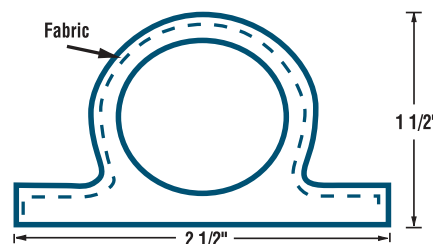

PRS938

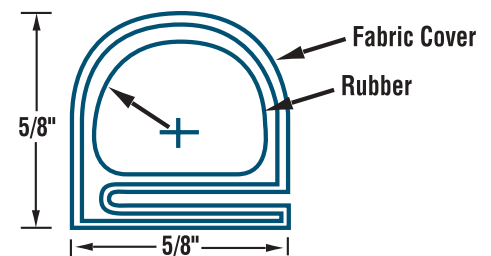

PR11235

Compression Gaskets, Trim, Bumpers & Non-Inflatable Profiles

The profiles on these pages can be supplied unfinished or as continuous loops, rectangles, or other finished configurations.

Double Bulb

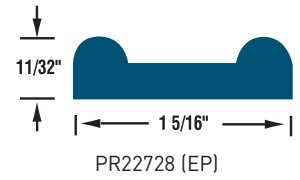
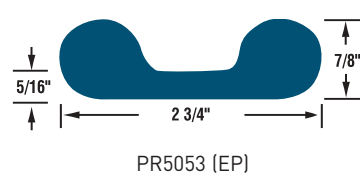
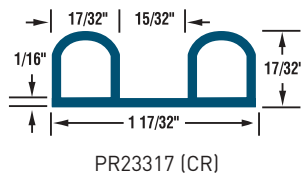
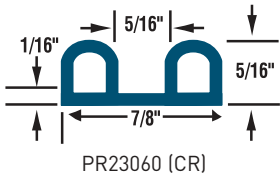

"P" Strips

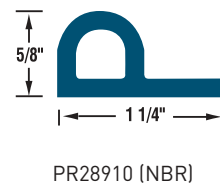
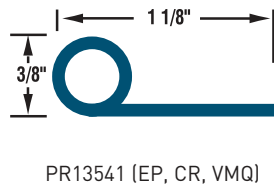
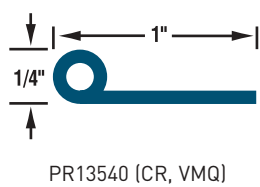

"J" Seals

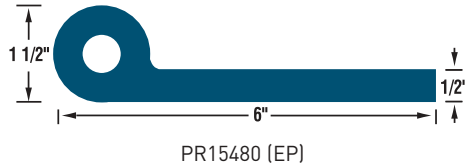
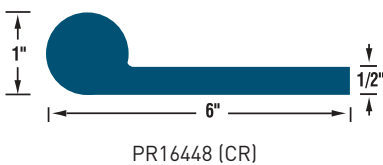
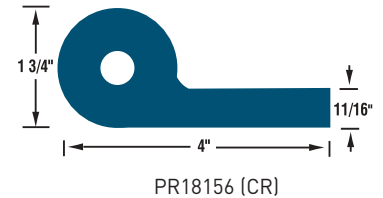
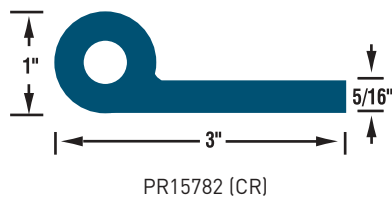
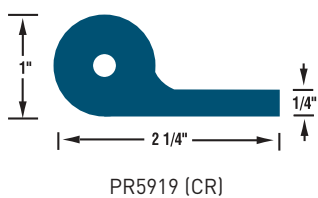

Channels

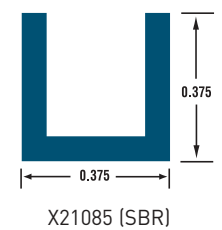
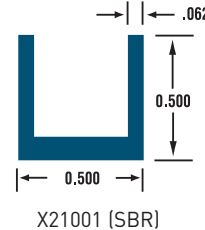
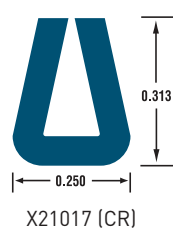
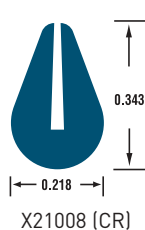
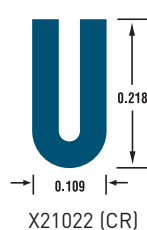
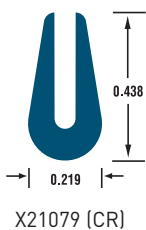

Center Bulb Seals

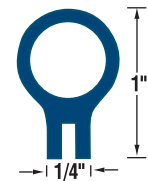

PR29658 (EP)

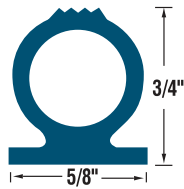

PR6473 (EP)

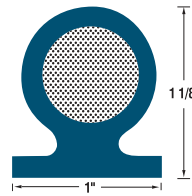

PRS914 (VMQ Sponge Core, EP)

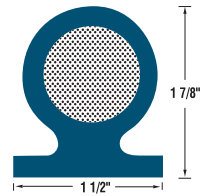

PR8133 (VMQ Sponge Core, EP)

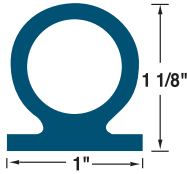

PR4264 (EP, NBR)

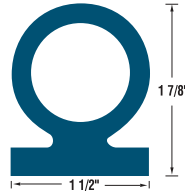

PR8122 (EP)

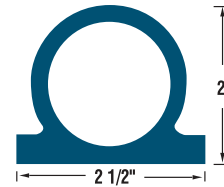

PR6881 (EP)

"D" Seals

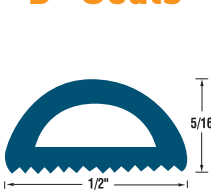

PR30470 (CR)

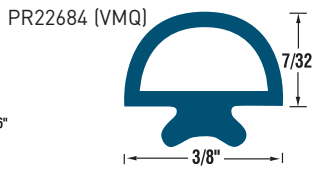

PR22684 (VMQ)

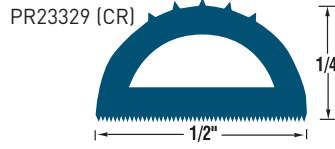

PR23329 (CR)

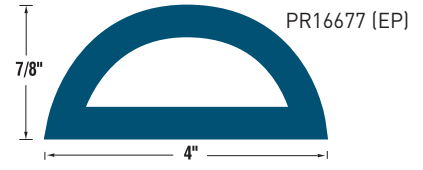

PR16677 (EP)

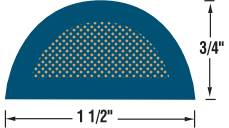

PR8075 (VMQ Sponge Core, EP)

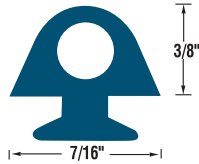

B100 (EP)



X21198 (CR)



PR16676 (EP)

Bumper Seals

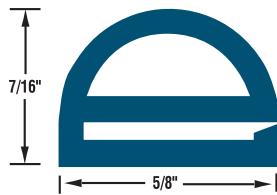

X31022 (VMQ)

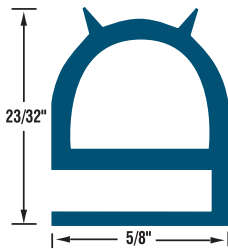

X31042 (VMQ)

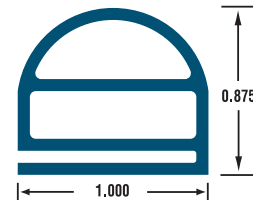

X31050 (VMQ)

Gumdrop Seals

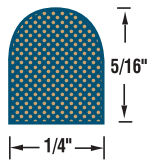

PR28692 (Sponge, VMQ)

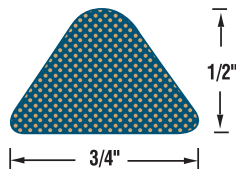

PR7966 (Sponge, VMQ)

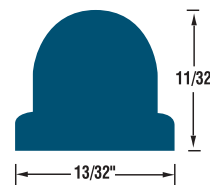

PR18085 (CR)

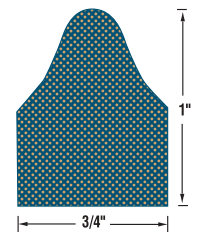

PR9131 (Sponge, VMQ)

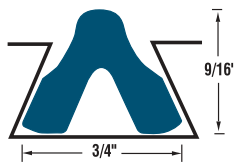

PR6268 (EP)

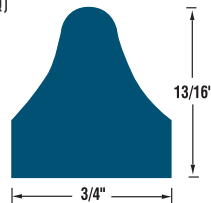

PR9686 (EP)

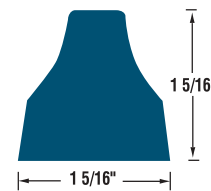

PR15347 (EP)

NOTE: For your convenience, you can photocopy the Pawling Design Service Specification form below.

To obtain Pawling design recommendations and pricing, please call or send the following information by fax or mail (a completed copy of this form would be helpful).

To: Pawling Design Service
 Company: _____ Name: _____
 Phone: _____ Fax: _____ Email: _____

Sealing against: Air _____ Water _____ Gas _____ Steam _____
 Other (describe) _____
 Gap _____ Pressure differential across seal (See Below) _____

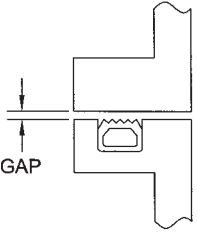

Gap = Clearance between deflated seal and opposing surface

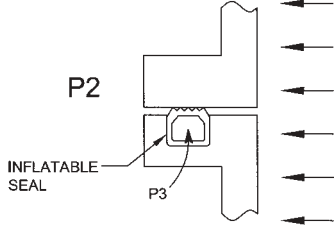

INFLATABLE SEAL

P1 = Pressure inside the vessel or equipment
 P2 = Outside
 P3 = Inflation pressure
 Pressure differential = P1 - P2
 Example: If P1 is 14.7 psig (1 bar) and P2 is atmosphere, pressure differential is 14.7 psig (1 bar)

Diameter or overall dimensions of seal _____
 Corner Radius (if available) _____ Max. deflated profile height & width _____
 Axial expanding _____ Radial expanding in _____ Radial expanding out _____
 Temperature _____ Other environmental factors _____
 Frequency of inflation _____ Duration of inflation _____
 Other remarks _____

 Required prototype quantity _____ and need date _____
 Estimated annual quantity requirements _____
 Sketch:



Pawling Engineered Products Division
 157 Charles Colman Boulevard
 Pawling, New York 12564-1193
 (845) 855-1000 • Fax (845) 855-1139

West Coast: (949) 475-9842
 E-Mail: info@pawling.com
 www.pawling.com